

CURRENT TRENDS IN FREE MOTION PRESSES

K.Miyoshi

Komatsu Industries Corp.

5 Yookaichimachijigata, Komatsu City, Ishikawa-Pref 923-8666, Japan

Industrial summary

The history of press machines is very long among industrial machinery, but its evolution has been very slow.

For example, the driving mechanism and the slide motion of press machines have not shown remarkable advance in the last 40 years since a link mechanism and a link motion were introduced through the technical cooperation of European and American advanced countries in the 1960s.

In this sense, the recent appearance of servo presses was an epoch-making event that would change and expand the possibility of press production techniques.

1.Introduction

Since our company, Komatsu Industries Corp., introduced the hydraulic servo press HAF in 1994, we have advocated the concept of the "Free motion press". This concept has been adopted from use with the initial hydraulic servo press to the AC servo press, which is clean and superior in the maintainability.

The concept has been realized through the introduction of the AC servo press HCP3000 in 1998, the hybrid AC servo press H2F, H4F series in 2001 and the hybrid AC servo press H1F series in 2002. (Fig.1)

At present, the development of our servo press is limited to stamping presses. But as the concept of "free motion" can be applied not only to stamping but also to forging, the development of the forging press will also happen soon.

In this paper, by introducing the servo press of our company, possibilities of servo press are described, and finally an application for the forging are discussed.

2.Concept of Servo Press

The servo press is a free motion press, which can realize an optimum slide motion that is tailor-made for production needs. The efficiency of a servo press versus a conventional mechanical press (crank press, link press) or a hydraulic press is shown in Fig. 2.

The concept of the servo press, which our company proposes, is as follows:



Fig.1 Line-up of Komatsu CNC Servo Press

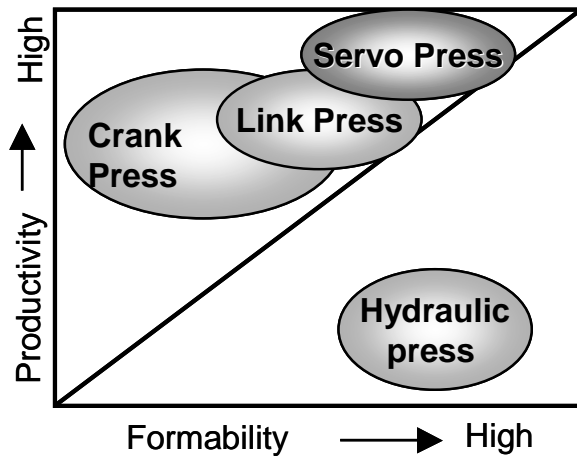

Fig.2 Positioning of servo press

1) Super high productivity

In the case of the servo press, the length of the stroke is changeable, so only the stroke length required for production is used. In addition, by setting the slide motion, which realizes effective synchronization with the carrying device, productivity can be improved.

2) Super high accuracy

For each point of the press, one unit of an independent driving source and a linear sensor is assembled. The slide position is controlled by the fully closed feedback. The slide position fluctuation at the bottom dead center and the slide parallelism fluctuation by the eccentric load between points are limited to $\pm 10 \mu\text{m}$. This accuracy is not dependent on the press size.

3) Super flexible

The optimum slide motion, which is determined by the production type and dies such as blanking, drawing, sheet forging, progressive dies, transfer dies, can be set, and the press production with high additional value is easily formed.

4) Super low noise

The driving mechanism is simple and the noise produced by the press machine is small. In addition, by setting the low noise motion, blanking noise can be reduced. For example, in order to reduce the blanking noise, it is known experientially that by executing the two-step blanking, in which the punch is once stopped at a half way of the blanking process

and soon driven again to finish the process, the blanking noise can be reduced. In the case of a conventional mechanical press, such motion cannot be realized, but this can be realized easily using the servo press.

Fig.3¹⁾ shows the data that the blanking noise is measured while changing the slide motion during the blanking process. In the Fig., indicates the blanking noise by the constant punch speed which represents conventional slide motion. indicates the blanking noise when the stopping position of punch is changed in the two-step blanking motion. From this Fig., it is understood that by using the two-step blanking motion, in which the stopping position is optimally adjusted, the level of blanking noise can be decreased more than 10dB in comparison with the conventional blanking.

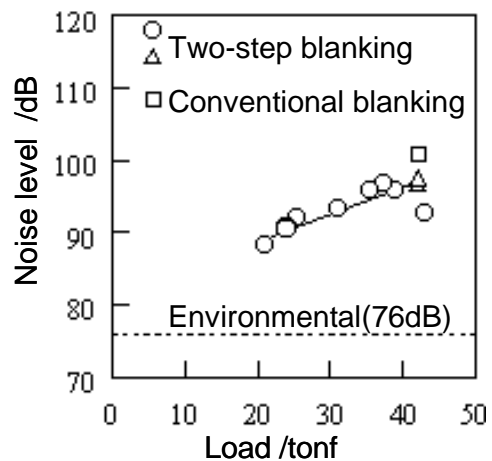

Fig.3 Blanking noise level by two-step blanking of HCP3000¹⁾

5) Super energy saving

In comparison with the mechanical press, the clutch brake and the flywheel do not exist, and the number of gears is lower. Therefore, the structure is simple and the maintainability is superior. Especially, because there are no sliding portions such as the clutch brake, little press lubricant is needed, and oil deterioration is small. In addition, by using the electricity generated when reducing the speed of the motor, electrical consumption is reduced.

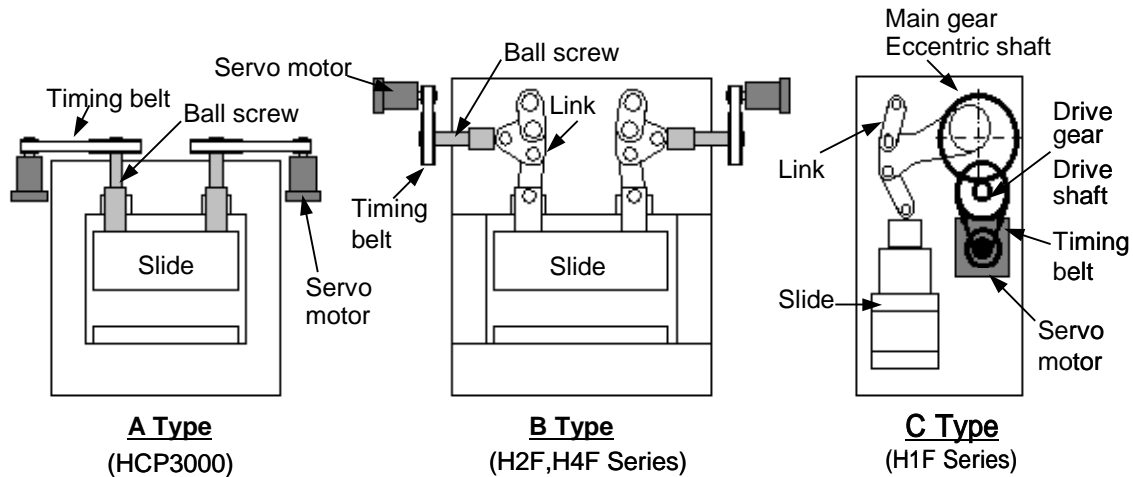

Fig.4 Driving mechanism of servo press

3. Driving mechanism of servo press

At present, Komatsu servo presses use 3 types of driving mechanisms as shown in Fig. 4. The feature of each driving mechanism is described as follows.

1) A type

This is the driving mechanism of firstly developed AC servo press HCP. The mechanism is simple. The rotation of the servo motor is transmitted to the ball screw by the timing belt and the slide is moved up and down by the reciprocating motion of the ball screw.

Like hydraulic presses, max. load can be generated from any position in the overall slide stroke. In addition, the slide motion flexibility is high and any motion setting is possible.

On the other hand, because the load is generated by combining the ball screw with the servo motor, the press capacity is limited by the strength of the ball screw and the power of servo motor. For this reason, the large capacity presses are difficult to construct using this mechanism.

2) B type

This is a hybrid mechanism used for H2F and H4F series. The rotation of the servo motor is transmitted to the ball screw by the timing belt.

The link mechanism is swung by the reciprocating motion of ball screw, and, by this swing, the slide is moved up and down. This type enables the larger press capacity, and the flexibility for the slide motion is similar to the A type.

On the other hand, because the link mechanism is adopted, it has the characteristic that the load generated changes according to the slide position, which is similar to the mechanical press.

3) C type

The driving mechanism of this type is used for the one point servo press H1F series, and this is the hybrid mechanism, by which the drive shaft of the link press is driven by the servo motor through the timing belt.

This differs from A and B types. The slide can be moved up and down without the reversed servo motor operation. Therefore, this is suitable for continuous operation at high speed.

Finally, Fig. 5 shows how each driving mechanism covers the forming range. In the left fig., the relationship between the press capacity and the max. stroke length is shown, and in the right fig., the relationship between the max. speed and the max. stroke length is shown.

4. Applying servo press to forging

Mg alloy is superior in specific strength, heat radiation, anti dent, magnetic shield ability, touch and aesthetic, and is more broadly used for the housing of household electrical appliances.

Many studies have been done concerning press forming of Mg alloys in the stamping filed, for example drawing. The merit of stamping is that the forming load is comparatively small while the shape is limited. On the contrary, forging, though a large load is required, can produce a complex shape with high value.

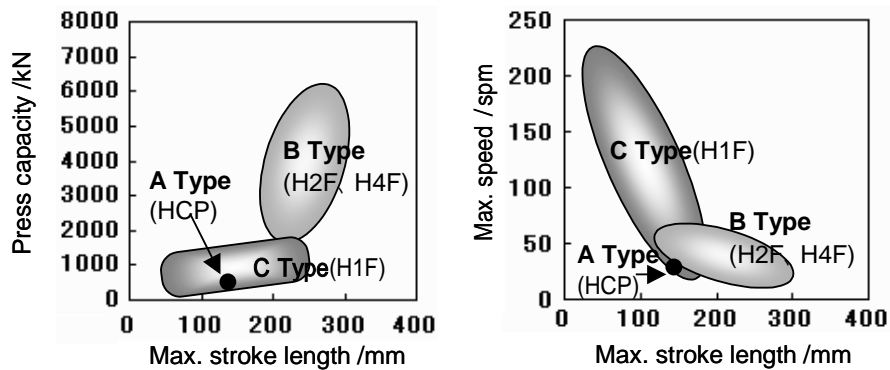

Fig.5 Forming range of servo press

Here, an example of MG alloy forging is introduced with the advantageous characteristics of the servo press.

In the case of Mg alloy, the press forming at room temperature is impossible. Therefore, a work piece has to be heated to 250 ~ 350 before forming. Further, because most objective production of MG alloy has a structure of thin plate such as the housing of household electric appliances, many cases of the shape of work piece are a thin plate with a broad surface. For this reason, the temperature of a heated work piece cools easily on the die and it is difficult to press-form under the required heated and constant temperature condition. But when the servo press is used, the material can be sandwiched between lower and upper dies controlled specified temperature and formed to the production shape when the material reaches the proper temperature. For this purpose, a furnace is not required and the control of forming temperature becomes easier. In addition, the work piece, which oxidizes easily when heated, can be formed without exposing it to the atmosphere. Therefore, the oxidation of the work piece surface can be prevented.

4.1 Result of heating test for Mg alloy plate by dies

Fig. 6 shows the heating time of Mg alloy when a Mg alloy of 30 x 3.0mm is heated by using the flat dies shown in Fig.7. In the upper and the lower dies, the thermo couples are positioned at 1.5mm inside the die surface at the die center. The temperature of the die is controlled by the heater so that the temperature of the thermo couple becomes 250 . The temperature of the work piece is measured by the thermo couple, which is buried at the position shown in Fig.8.

As shown in Table 1, the work pieces are heated in such a way that the distance

between the upper and lower die is kept at 3.0, 3.1 and 3.2mm respectively. Further, in the state that the die is held at 100kN force. Totally, 4 levels are tested

In Fig. 6, the heating time, at level 1 in which the die is kept in the position where the die perfectly contacts the work piece, and at level 4 in which the die is pushed to the work piece by the constant load, are almost equal. But, strictly speaking, the heating time of level 4 is a little shorter.

On the other hand, in the case of the level 2 that the clearance between the die and the work piece is 0.1mm, the heating time of work piece to 250 is delayed approx. 3sec in comparison with level 1. Further, in the case of level 3, where the clearance between the die and the work piece is 0.2mm, the time is delayed 8sec in comparison with level 1, but the temperature of the work piece does not rise to the specified 250 .

Using the above results, when there is clearance between the die and the work piece, the heating time of the work piece varies. In the actual forming, the thickness of work pieces varies. Therefore, it is desirable to push the die to the work piece using the specified force in order to heat the work piece evenly.

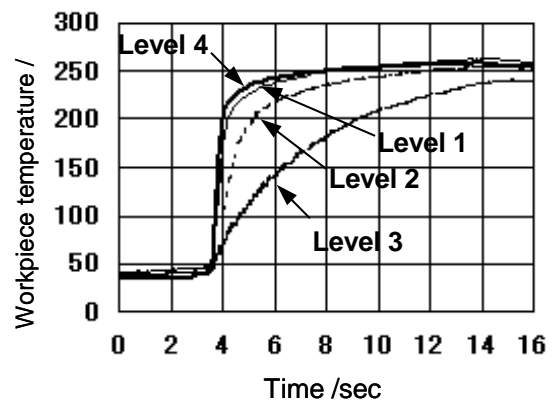

Fig.6 Heating time of Mg alloy

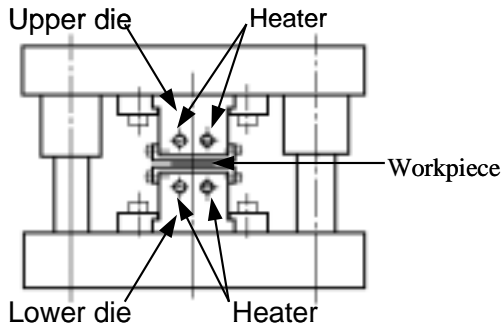

Fig.7 Heating test die

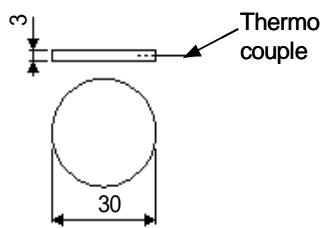

Fig.8 Workpiece shape

Table 1. Temperature rising test level

Test Level	Die control method	Die stop position Die hold load
1	Stop at constant position	3.0mm
2		3.1mm
3		3.2mm
4	Hold at constant load	100kN

4.2 Hot Sheet forging of Mg alloy by servo press

The next example is cup forming with a protrusion of 5mm x 5mm in the center by backward extrusion of Mg alloy (Material AZ31). (Fig. 11)

The servo press HCP3000 was used and the size of the work piece was 30mm x 3mm. Fig. 9 shows the die structure and the die motion and Fig.10 shows the slide motion of the servo press.

From position A in which a work piece at room temperature is set to the die, to position B in which the top and the bottom dies are in contact with the work piece, the slide lowers at the speed of 150mm/sec. And slide lowers at the speed of 6mm/sec from position B to position C. During this time the work piece is caught between the upper punch and the counter-punch, and pushed by the spring force which holds the counter-punch, so that it perfectly contacts with the punch, and it is heated up to 300 °C. And from position C where the forming starts, the slide lowers at the speed of 2mm/sec, and stops at the bottom dead center for 0.3sec, and reaches position D that the forming ends. After that, it rises at 150mm/sec. Molybdenum disulfide was used as die lubricant.

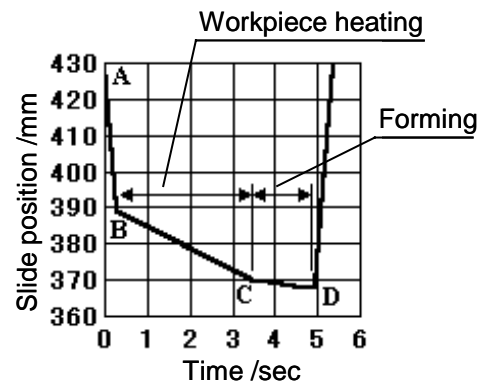

Fig.10 Slide motion of Mg alloy forging

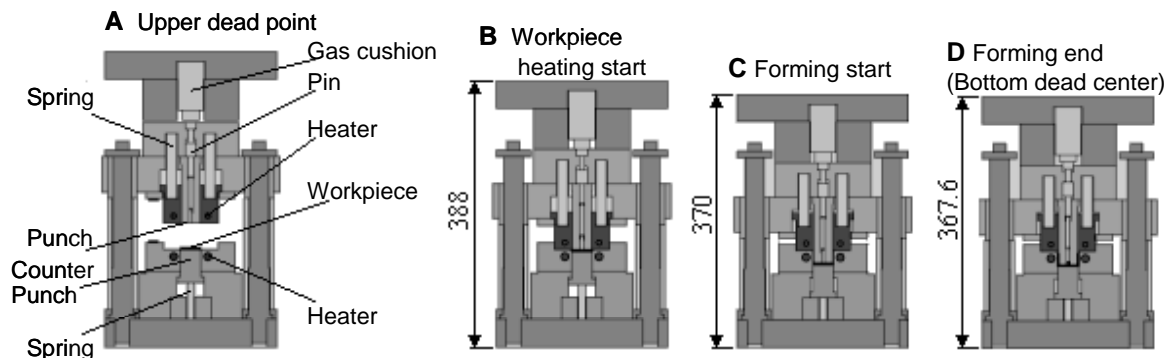

Fig.9 Die structure for Mg alloy forming and its motion

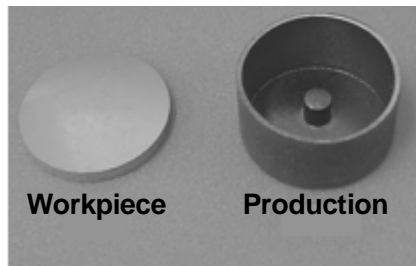

Fig.11 Mg alloy workpiece and Production

5. Afterword

The AC servo press is the press machine that enables press forming which was almost impossible in the past.

On the other hand, because this press has no energy accumulation device (Like the flywheel of the mechanical press and the accumulator of the hydraulic press), it is not proper for large working energy forming at this time.

The AC servo press is still under evolving now. Due to the progression of each component (AC servo motor, ball screw, etc.) of the servo press, and the progression of control methods for each driving mechanism, the application range of the servo press will expand greatly in the near future. Further, the appearance of new driving mechanism is expected. The speed of the evolution, compared to conventional press history, will be very high.

Acknowledgement

The heating test of Mg alloy and the forming trial of the cup shown in Section 4 were performed in cooperation with assistant professor Shiraishi and Dr. Niikawa of Fukui University, Dr. Taga of the Industrial Research Institute of Ishikawa. Here, we would like to express our gratitude.

Reference

- [1] C.Yamagata, M.Otsu, K.Osakada: The proceedings of the 2002 japanese spring conference for the technology of plasticity,pp.161-162,(2002)